

HATFIELD TOWNSHIP

DECK/PATIO PERMIT PROCEDURES

A deck/patio permit is required for all construction including decks, renovation of existing decks/patio, paver patios, and retaining walls (over 30 inches).

PART I – Location of Property – Address, Zoning District, Parcel Number and Lot & Block must be provided on all applications.

PARTS II thru VI – Complete every section.

PART VII – Sign and date application. If property resident is not the owner of the property, a notarized statement indicating the owner's approval of the proposed construction must be submitted with the application. Provide phone numbers where property owner/resident and contractor may be reached. Contractors making application must be registered with the township prior to starting construction.

PART VIII - Property Diagram – Show all dimensions of entire property (length x width and square feet of entire lot). Identify streets adjacent to property. Place all buildings, with size dimensions (length and width) indicated, within property lines and indicate whether existing or proposed. Indicate front yard, side yard, and rear yard setbacks by showing the distance from deck to property lines on all sides. **The property owner is responsible for the accuracy of this plot plan. On-lot sewage disposal systems and/or any easements/deed restrictions must be indicated.**

PLANS AND SPECIFICATIONS

- **Two (2) copies of all plans and specifications must be submitted with all applications for deck permit. Cross Section Drawings, giving structural details as outlined below, must be included. (See sample drawings attached).**
 - **An Earth Disturbance Permit Application must also be included if improvements result in 1,000 or more square feet of new impervious surface and/or 1,000 square feet or more of earth disturbance. Please see permit for instructions regarding stormwater requirements. A Stormwater Management and Best Management Practices Operations and Maintenance Agreement must be signed by applicant or homeowner(s) prior to issuance of permits.**
- A. **DIMENSIONS** – Show all dimensions of proposed deck – height (ground level to highest point of roof), width and length. Give overall floor plan showing all dimensions.
- B. **PIER/ FOOTINGS (SEE G)** – Give all foundation information – depth of excavated footings to the finished grade and width of footings. Indicate depth of concrete in footings (minimum 36”). Indicate PSI (pounds per square inch) of concrete and/or other sub-materials.
- C. **MAIN BEAMS (SEE G)** – Give size and description of materials of beam and column supports. Spans between columns must be indicated. If using *Manufactured Beams*, structural plans must be sealed by engineer or architect.
- D. **FLOORS (SEE G)** – Indicate joist direction, span, size, spacing, bridging, and anchorage to foundation. Show type and thickness of floor.
- E. **WALL** – Indicate wall plates, stud size and spacing, type and placement of bracing, details of exterior materials, and door and window headers. Indicate span of cantilever. Show railings and or guards with height and spacing of all balusters where needed.

- F. **CEILING & ROOF FRAMING (SEE G)** – Indicate size, spacing, direction, and span of joists. Roof rafters must show pitch, size, span, and spacing. Indicate spacing of collar ties. Roof sheathing and type of roof materials to cover it should be shown. If using *Manufactured Roof Trusses*, structural plans must be sealed by engineer or architect.
- G. **ATTACHING TO EXISTING STRUCTURE** – Indicate method of attachment of items B through F above of the proposed structure to the existing structure, if applicable.

ADDITIONAL INFORMATION

FEES – Permit fees must be submitted with the permit application. If paying by check, please make check payable to “Hatfield Township”.

REVIEW – The application will be reviewed by the Code Enforcement and Zoning Departments for compliance with all Township codes and ordinances.

PERMIT GRANTED – **If approved, the permit will be processed and issued to you within fifteen (15) business days. Work may not start until a permit has been approved and granted.** The permit cards are to be displayed so as to be visible from the street.

PLUMBING, ELECTRICAL AND HVAC – All plumbing, electrical, heating and air conditioning contractors and/or their personnel must be registered and provide a Certificate of Insurance verifying Worker’s Compensation coverage, and Federal or State Employer Identification Number (EIN). In addition, each contractor must obtain the appropriate permits for the work to be done. All electrical work must be inspected by United Inspection Agency.

INSPECTIONS – Call the Township office (215-855-0900) at least 24 hours in advance to schedule each inspection. Responsibility for notification for inspections at the various stages of construction lies with the applicant and/or contractor. If the appropriate inspections are not requested, uninspected work will not be granted final approval. **If an inspection fails twice for the same code violation, a reinspection fee will be required prior to a third inspection.**

HATFIELD TOWNSHIP

Application for Deck/Patio Plan Examination and Permit

I - LOCATION OF PROPERTY

Address: _____ City: _____

Parcel #: 35-00 _____ Lot: _____ Block: _____

II - OWNERSHIP

Private Public Tenant Other _____

III - IDENTIFICATION – To be completed by all applicants

APPLICANT Name: _____ Phone: _____

Company: _____

Address: _____

City: _____ State: _____ Zip Code: _____

Email Address: _____

OWNER Name: _____ Phone: _____

Address: _____

City: _____ State: _____ Zip Code: _____

CONTRACTOR Company: _____ Phone: _____

Name: _____

Address: _____

City: _____ State: _____ Zip Code: _____

State License Number: _____ Expiration Date: _____

DESIGN PROFESSIONAL Name: _____ Phone: _____

Address: _____

City: _____ State: _____ Zip Code: _____

IV - TYPE OF CONSTRUCTION OR IMPROVEMENTS

Deck Patio Retaining Wall **Square Footage of Construction Area** _____

New Alteration/Renovation Repair or Replacement

V - COST

Cost of Construction Improvements \$ _____

VI - FEES \$ _____

VII - SIGNATURE

Deposit of Check Representing the Fee for this Application does not Constitute Approval of or Granting of Same by Hatfield Township. I hereby certify that the proposed work is authorized by the owner of record and that I have been authorized by the owner to make this application as his agent and we agree to conform to all applicable laws of Hatfield Township.

SIGNATURE OF APPLICANT (Print & Sign)

DATE

VIII - SITE OR PLOT PLAN – See Sample Plot Plan (last page of instructions).

SCHEDULE OF FEES

ALL DECKS AND PATIO FEES: \$85.00

RETAINING WALL FEE: \$35.00

Note: All enclosed decks and patios require a home improvement building permit.

SAMPLE DECK FLOOR PLAN

LIST ALL DIMENSIONS IN FEET & INCHES

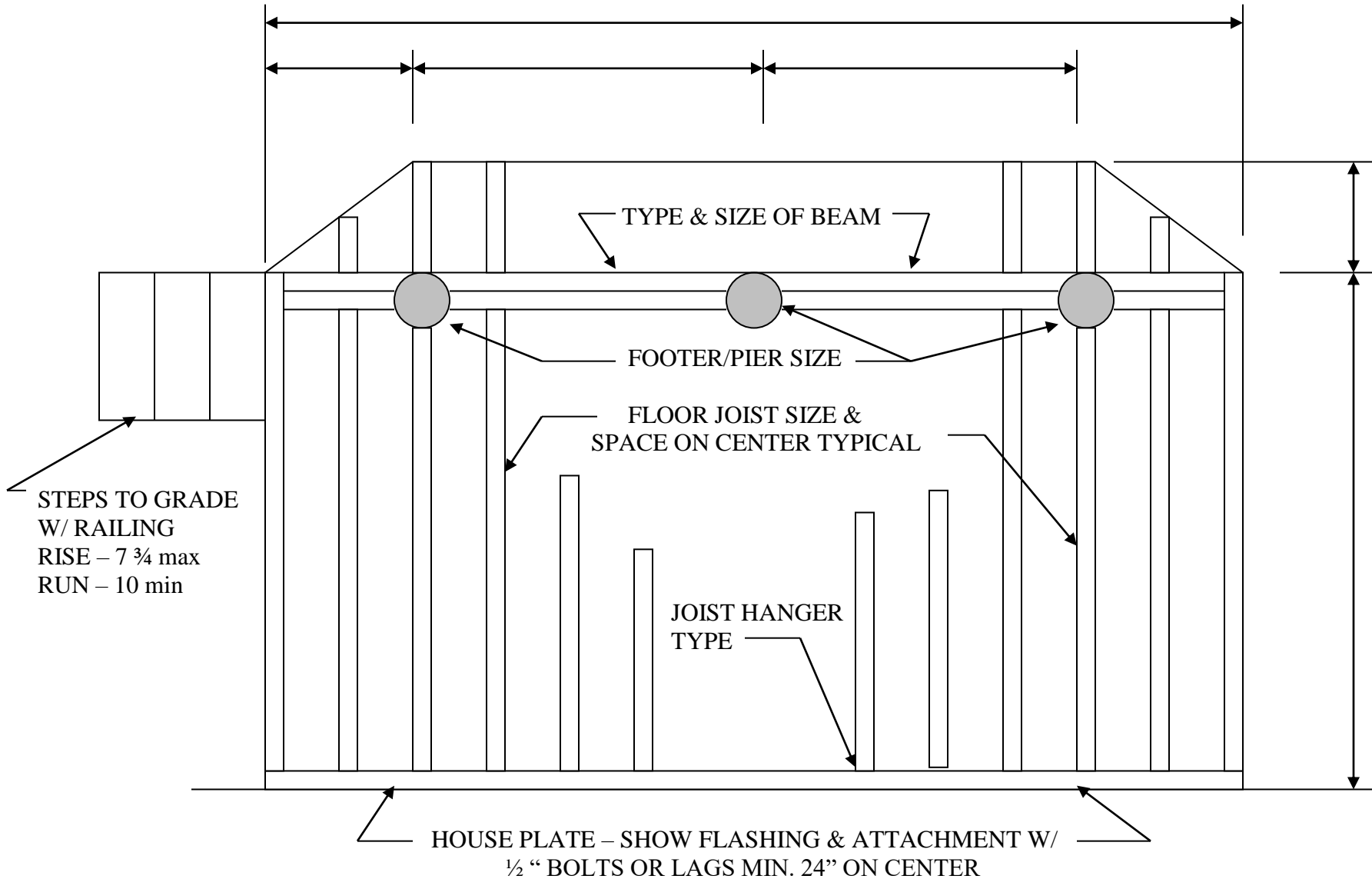

NOTE: THIS DETAIL DRAWING IS A **SAMPLE** ONLY. IT IS TO HELP IN SUMITTING YOUR DESIGN DETAILS AND THE INFORMATION THAT IS REQUIRED FOR CODE REVIEW.

REV.

SAMPLE DECK DETAILS

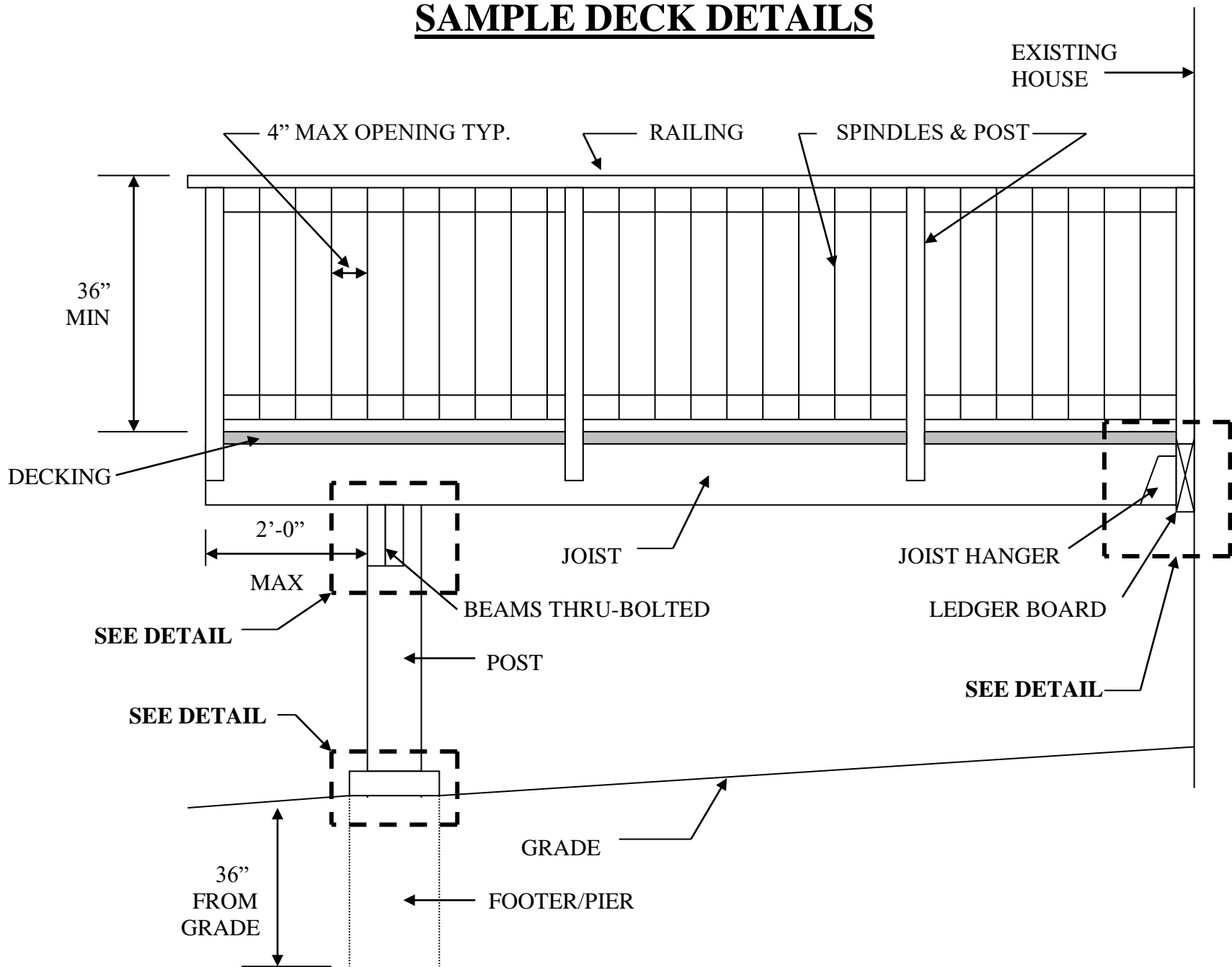

NOTE: THIS DETAIL DRAWING IS A **SAMPLE** ONLY. IT IS TO HELP IN SUMITTING YOUR DESIGN DETAILS AND THE INFORMATION THAT IS REQUIRED FOR CODE REVIEW.

RECOMMENDED BEAM, FOOTER TO POST DETAIL

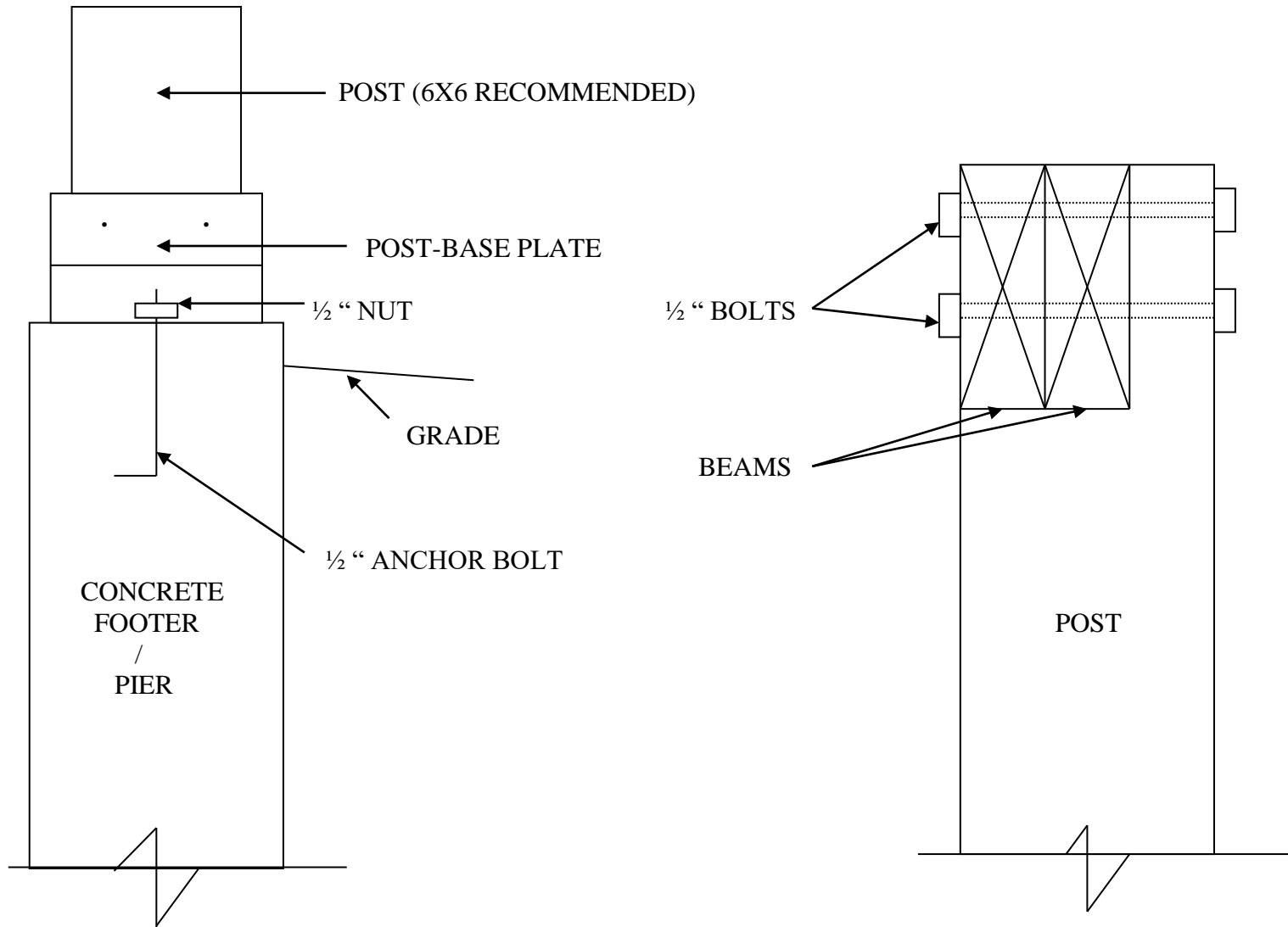

FOOTER/PIER TO POST DETAIL

POST TO BEAM DETAIL

NOTE: THIS DETAIL DRAWING IS A **SAMPLE ONLY**. IT IS TO HELP IN SUMITTING YOUR DESIGN DETAILS AND THE INFORMATION SHOWN IS REQUIRED FOR CODE REVIEW. EQUIVALENT TOO IN DESIGN WILL BE REVIEWED.

RECOMMENED FLASHING AND LEDGER BOARD DETAIL

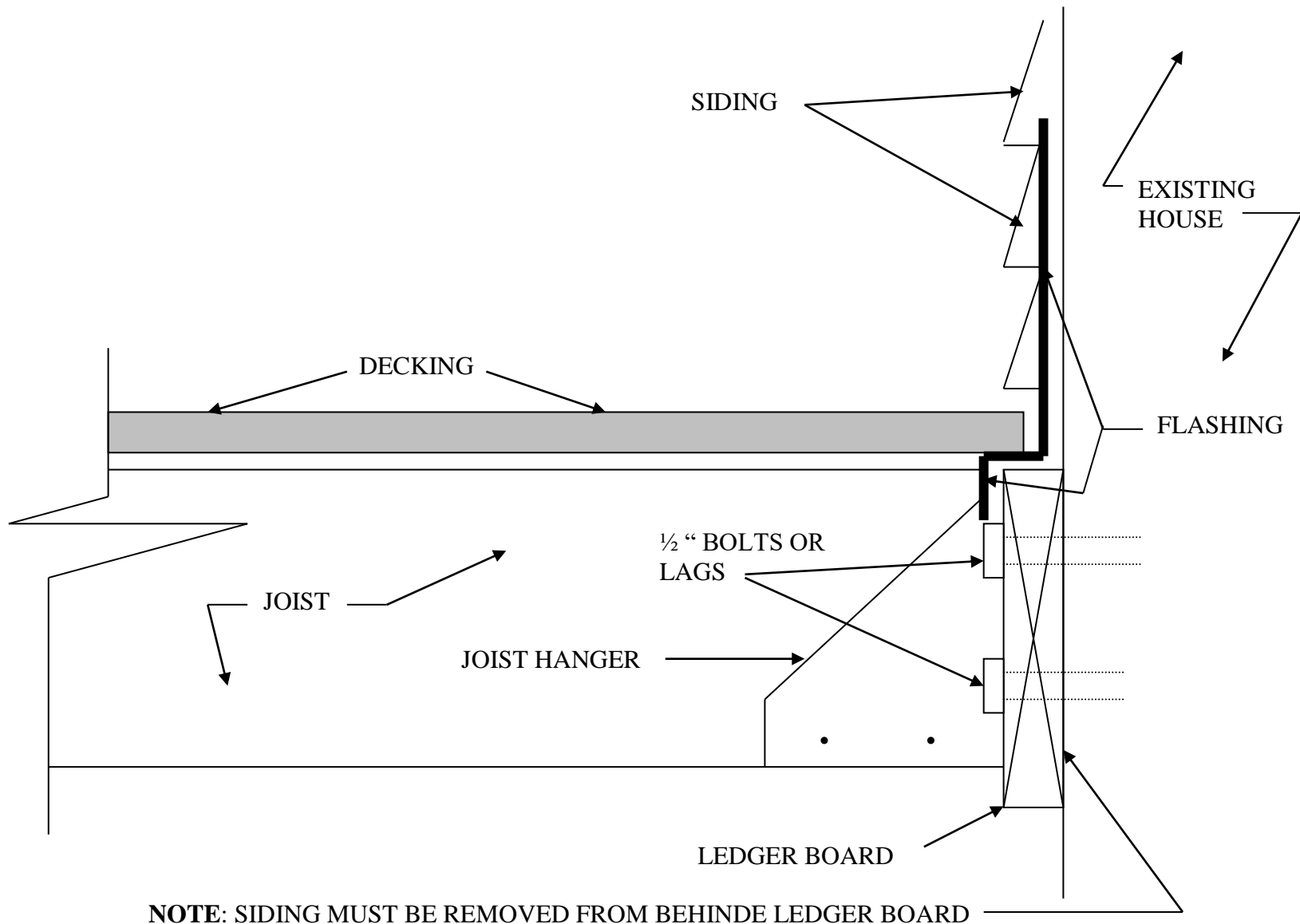

NOTE: THIS DETAIL DRAWING IS A **SAMPLE ONLY**. IT IS TO HELP IN SUMITTING YOUR DESIGN DETAILS AND THE INFORMATION SHOWN IS REQUIRED FOR CODE REVIEW. EQUIVALENT TOO IN DESIGN WILL BE REVIEWED.

SLAB - SAMPLE DRAWINGS

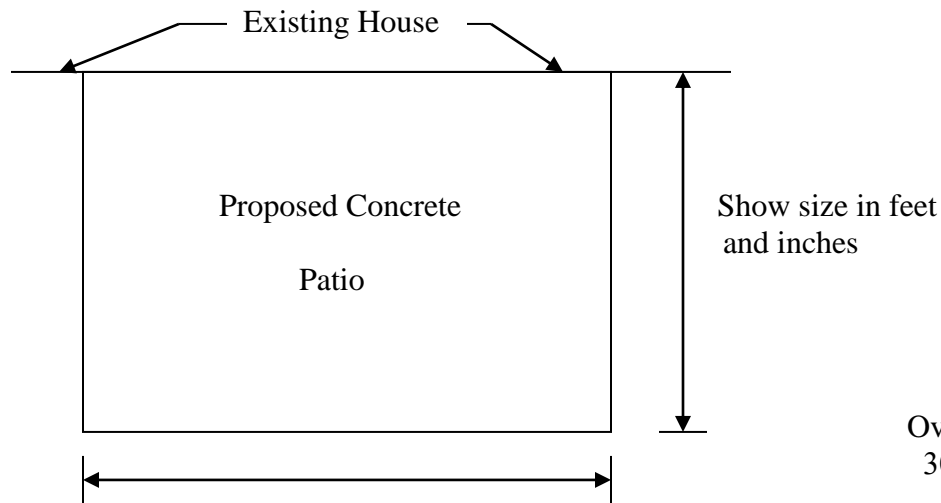

NOTE: THIS DETAILED DRAWING IS A **SAMPLE** ONLY. IT IS TO HELP IN SUMITTING YOU'RE DESIGN DETAILS AND THE INFORMATION THAT IS REQUIRED FOR CODE REVIEW.

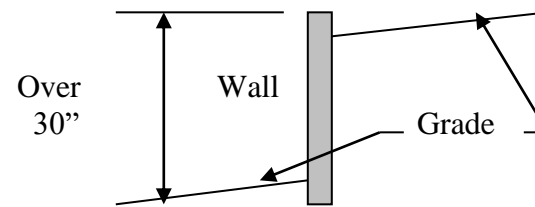

RETAINING WALL

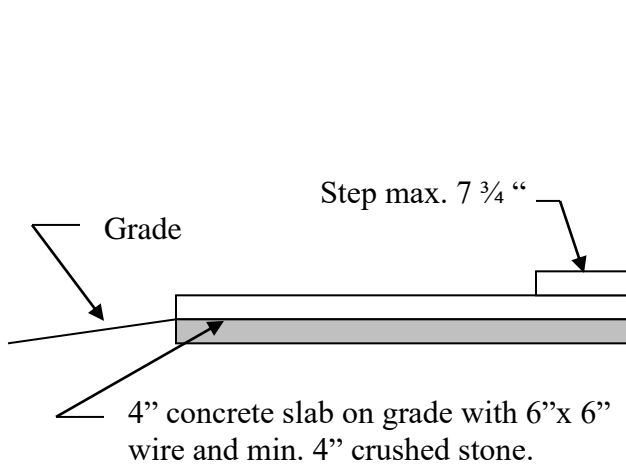

All concrete 3000 PSI

SLAB ON GRADE

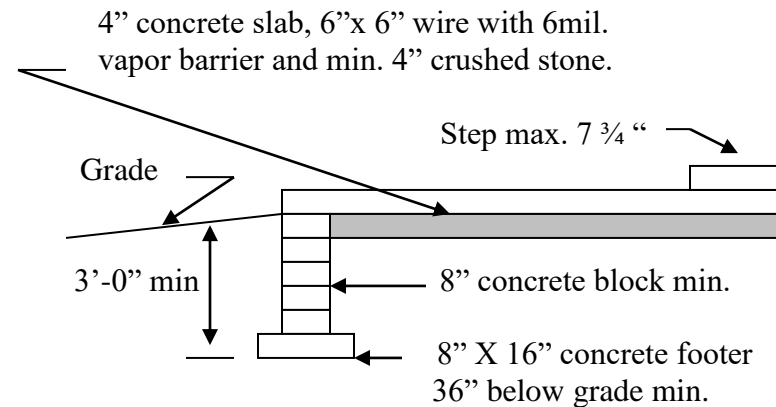

All concrete 3000 PSI

SLAB ON FOOTERS FOR FUTURE ROOM

SAMPLE PROPERTY DIAGRAM

SHOW ALL SETBACKS, LOCATIONS OF PROPOSED IMPROVEMENTS
AND ALL PHYSICAL CHARACTERISTICS OF PROPERTY

